

Features

- Diaphragm poppet valves suitable for controlling air-inert gas and liquids.
- Internal piloting controls large orifices to provide high flows.
- Can be used to pilot large actuators to provide quick closing of large control valves.
- Resilient seating for tight shutoff.
- Mountable in any position.

Construction

Valve Parts in Contact with Fluids	
Body	Brass
Seals and Disc	NBR
Diaphragm Assembly	NBR
Core Tube	305 Stainless Steel
Core and Plugnut	430F Stainless Steel
Core Springs	302 Stainless Steel and 17-7PH Stainless Steel
Shading Coil	Copper
Pilot Seat Cartridge and Disc-Holder	CA

Electrical

Standard Coil and Class of Insulation	Watt Rating and Power Consumption				Spare Coil Part No.			
	DC Watts	AC Watts	VA Holding	VA Inrush	General Purpose		Explosionproof	
					AC	DC	AC	DC
F	10.6	6.1	16	30	238210	238310	238214	238314
F	22.6	17.1	40	70	238610	238710	238614	238714

Standard Voltages: 24, 120, 240, 480 volts AC, 60 Hz (or 110, 220 volts AC, 50 Hz). 6, 12, 24, 120, 240 volts DC. Must be specified when ordering. Other voltages available when required.

Solenoid Enclosures

Standard: Watertight, Types 1, 2, 3, 3S, 4, and 4X.
Optional: Explosionproof and Watertight, Types 3, 3S, 4, 4X, 6, 6P, 7, and 9. (To order, add prefix "EF" to catalog number.) <i>See Optional Features Section for other available options.</i>

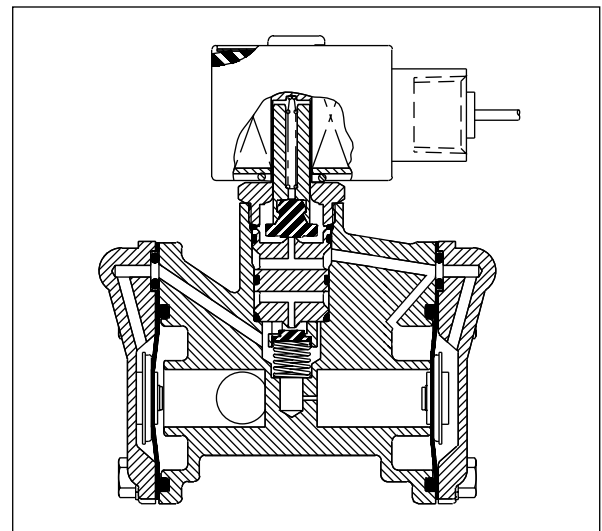
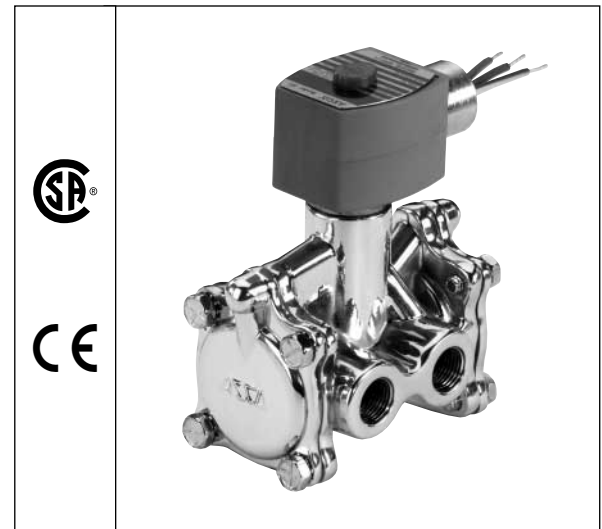

Nominal Ambient Temperature Ranges:

AC: 32°F to 125°F (0°C to 52°C)

DC: 32°F to 104°F (0°C to 40°C)

Refer to Engineering Section for details.

Approvals:

CSA certified. Meets applicable CE directives.

Refer to Engineering Section for details.

Important:

A minimum operating pressure differential must be maintained between the pressure and exhaust ports. Supply and exhaust piping must be full area, unrestricted. ASCO flow controls and other similar components must be installed in the cylinder lines only.

Specifications (English units)

Pipe Size (ins.)	Orifice Size (ins.)	Cv Flow Factor	Operating Pressure Differential (psi)				Max. Fluid Temp. °F		Brass Body		Constr. Ref. No	Watt Rating/ Class of Coil Insulation ②	
			Min. ①	Max. AC		Max. DC		AC	DC	Catalog Number		AC	DC
				Air-Inert Gas	Water	Air-Inert Gas	Water						
NORMALLY CLOSED (Closed when de-energized)													
3/8	5/8	3	10	150	125	125	125	180	120	8316G54	1	6.1/F	10.6/F
3/8	5/8	2.5	10	250	250	250	250	180	120	8316G14	2	17.1/F	22.6/F
1/2	5/8	3.2	10	150	125	125	125	180	120	8316G64	1	6.1/F	10.6/F
1/2	5/8	3.2	10	250	250	250	250	180	120	8316G24	2	17.1/F	22.6/F
3/4	11/16	4.8	10	150	125	125	125	180	120	8316G74	3	6.1/F	10.6/F
3/4	11/16	4.8	10	250	250	250	250	180	120	8316G44	4	17.1/F	22.6/F
1	1	12.5	10	150	125	125	125	180	120	8316G34	5	6.1/F	10.6/F
NORMALLY OPEN (Open when de-energized)													
3/8	5/8	2.5	10	150	125	125	125	180	120	8316G56	1	6.1/F	10.6/F
3/8	5/8	2.5	10	250	250	250	250	180	120	8316G16	2	17.1/F	22.6/F
1/2	5/8	3.2	10	150	125	125	125	180	120	8316G66	1	6.1/F	10.6/F
1/2	5/8	3.2	10	250	250	250	250	180	120	8316G26	2	17.1/F	22.6/F
3/4	11/16	4.8	10	150	125	125	125	180	120	8316G76	3	6.1/F	10.6/F
3/4	11/16	4.8	10	250	250	250	250	180	120	8316G46	4	17.1/F	22.6/F
1	1	12.5	10	150	125	125	125	180	120	8316G36	5	6.1/F	10.6/F
Notes: ① 10 psi Minimum Operating Pressure Differential required. Valve vents to "zero" psi. ② On 50 hertz service, the watt rating for 6.1/F solenoid is 8.1 watts.													

Specifications (Metric units)

Pipe Size (ins.)	Orifice Size (mm)	Kv Flow Factor (m3/h)	Operating Pressure Differential (bar)				Max. Fluid Temp. °C		Brass Body		Constr. Ref. No	Watt Rating/ Class of Coil Insulation ②	
			Min. ①	Max. AC		Max. DC		AC	DC	Catalog Number		AC	DC
				Air-Inert Gas	Water	Air-Inert Gas	Water						
NORMALLY CLOSED (Closed when de-energized)													
3/8	16	2.57	0.7	10	9	9	9	81	48	8316G54	1	6.1/F	10.6/F
3/8	16	2.14	0.7	17	17	17	17	81	48	8316G14	2	17.1/F	22.6/F
1/2	16	2.74	0.7	10	9	9	9	81	48	8316G64	1	6.1/F	10.6/F
1/2	16	2.74	0.7	17	17	17	17	81	48	8316G24	2	17.1/F	22.6/F
3/4	17	4.11	0.7	10	9	9	9	81	48	8316G74	3	6.1/F	10.6/F
3/4	17	4.11	0.7	17	17	17	17	81	48	8316G44	4	17.1/F	22.6/F
1	25	10.71	0.7	10	9	9	9	81	48	8316G34	5	6.1/F	10.6/F
NORMALLY OPEN (Open when de-energized)													
3/8	16	2.14	0.7	10	9	9	9	81	48	8316G56	1	6.1/F	10.6/F
3/8	16	2.14	0.7	17	17	17	17	81	48	8316G16	2	17.1/F	22.6/F
1/2	16	2.74	0.7	10	9	9	9	81	48	8316G66	1	6.1/F	10.6/F
1/2	16	2.74	0.7	17	17	17	17	81	48	8316G26	2	17.1/F	22.6/F
3/4	17	4.11	0.7	10	9	9	9	81	48	8316G76	3	6.1/F	10.6/F
3/4	17	4.11	0.7	17	17	17	17	81	48	8316G46	4	17.1/F	22.6/F
1	25	10.71	0.7	10	9	9	9	81	48	8316G36	5	6.1/F	10.6/F
Notes: ① 1 bar Minimum Operating Pressure Differential required. Valve vents to "zero" bar. ② On 50 hertz service, the watt rating for 6.1/F solenoid is 8.1 watts.													

Dimensions: inches (mm)

Constr. Ref. No.		H	K	L	P
1	ins.	5.08	3.08	2.76	3.94
	mm	129	78	70	100
2	ins.	5.26	3.15	2.76	4.12
	mm	134	80	70	105

Constr. Refs. 1,2

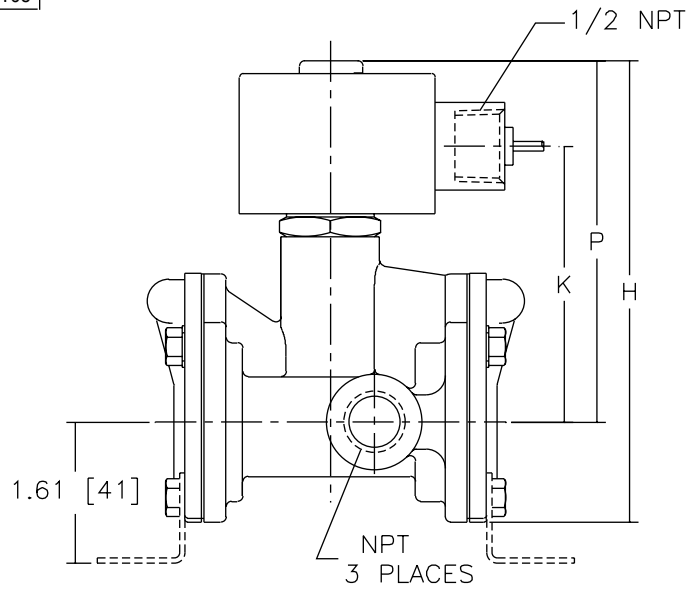

OPTIONAL MOUNTING BRACKET WITH $\phi.28$ [$\phi 7$] HOLES 4 PLACES

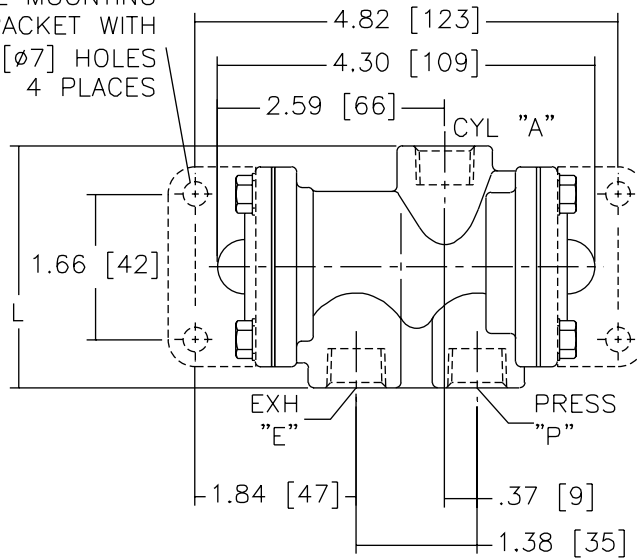

Dimensions: inches (mm)

Constr. Ref. No.		A	B	C	H	K	L	M	N	P	R	W
3	ins.	1.61	1.41	1.66	6.01	3.46	3.38	2.16	.53	4.32	.50	3.31
	mm	41	36	42	153	88	86	55	13	110	13	84
4	ins.	1.61	1.41	1.66	6.19	3.53	3.38	2.16	.53	4.50	.50	3.31
	mm	41	36	42	157	90	86	55	13	114	13	84
5	ins.	X	1.80	X	6.63	3.71	4.44	2.81	.88	4.57	1.74	5.32
	mm	X	46	X	168	94	113	71	22	116	44	135

Constr. Refs. 3, 4, 5

OPTIONAL MOUNTING BRACKET WITH $\phi.28$ [$\phi 7$] HOLES 4 PLACES AVAILABLE ON 3/4 SIZE ONLY

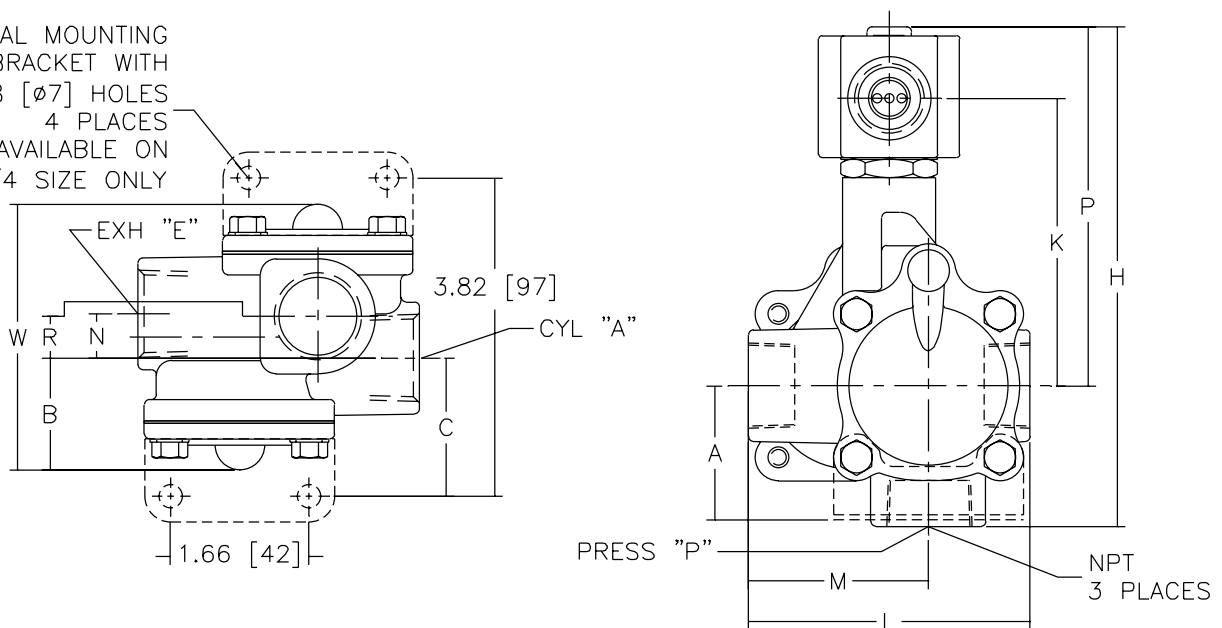

FLOW DIAGRAMS

